

RECOMMENDED P.C. BOARD LAYOUT FOR 1.57 THICK P.C. BOARD

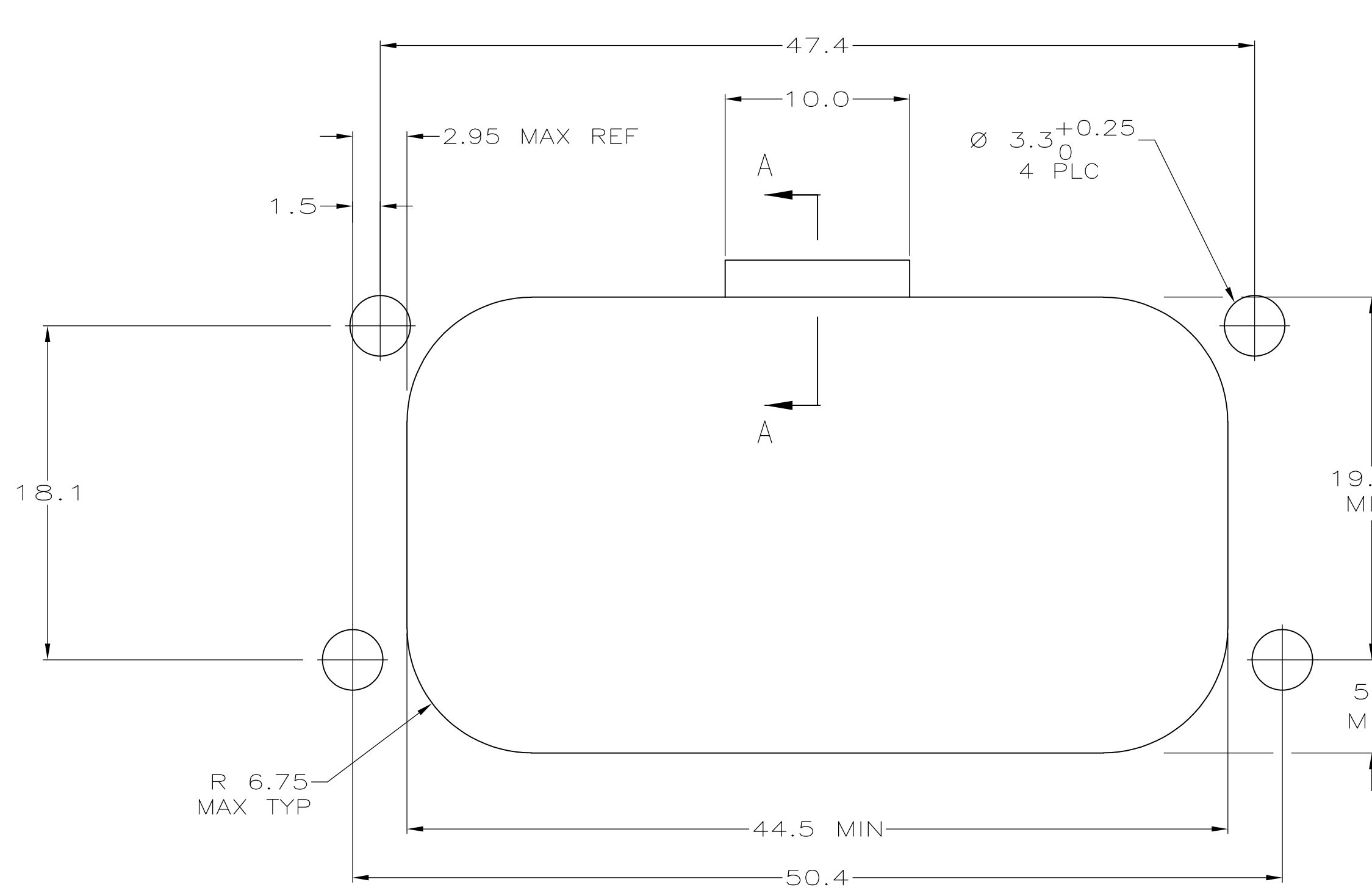

RECOMMENDED MOUNTING HOLE LAYOUT FOR 5.0 MAX THICK PANEL

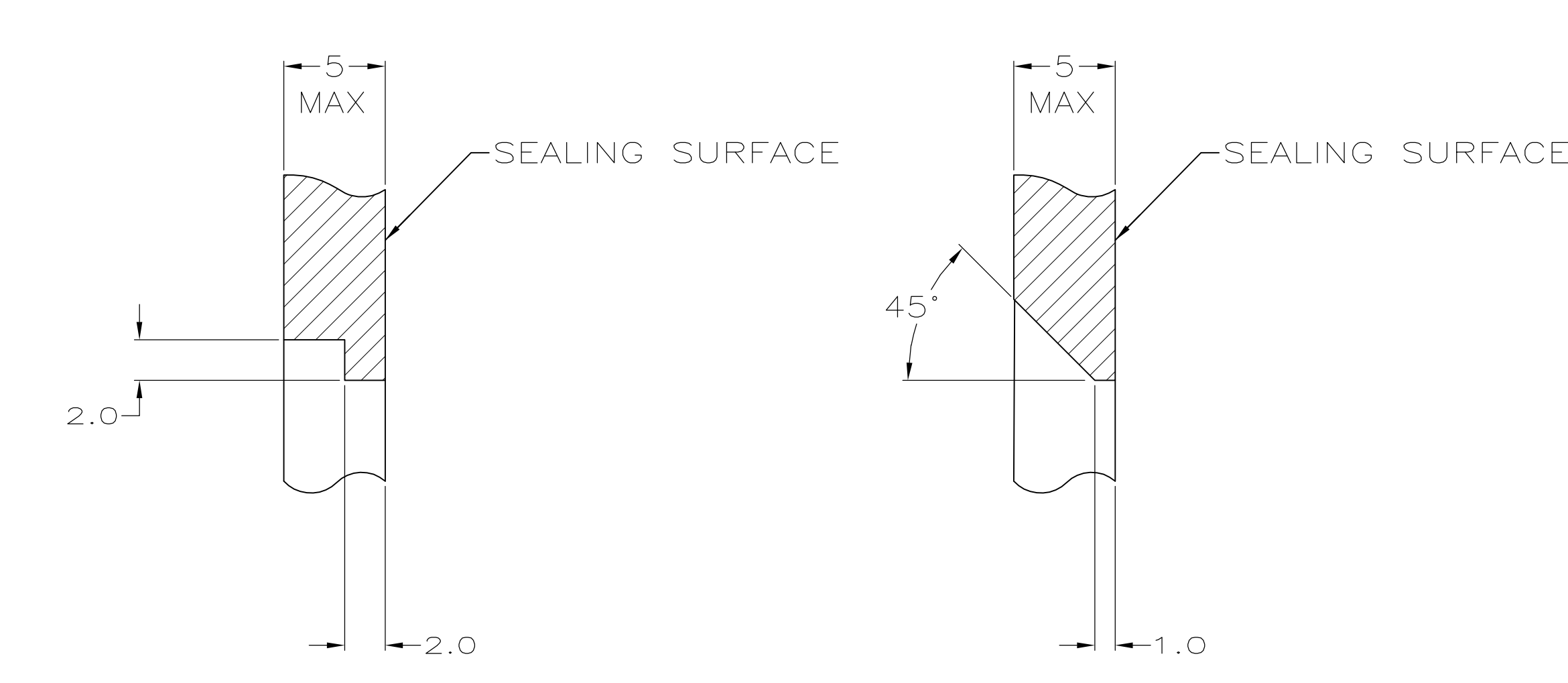

SECTION A-A OPTIONAL CONSTRUCTION IF THICKNESS IS GREATER THAN 2.0

- ⚠ ACCEPTS #4 SELF TAPPING SCREW (ELCO HI-LO THREAD CUTTING STYLE OR EQUIVALENT) TO BE DRIVEN AT 0.6±0.2 N-M.
- ⚠ HOUSING COLORS ARE MECHANICALLY KEYPED TO MATE ONLY WITH IDENTICALLY COLORED PLUG ASSEMBLIES.
- ⚠ GASKET TO BE MADE FROM SILICONE (TE P/N 0-0988206-1, SARA #33341). GASKET WILL BE U.V. CURED IN PLACE.

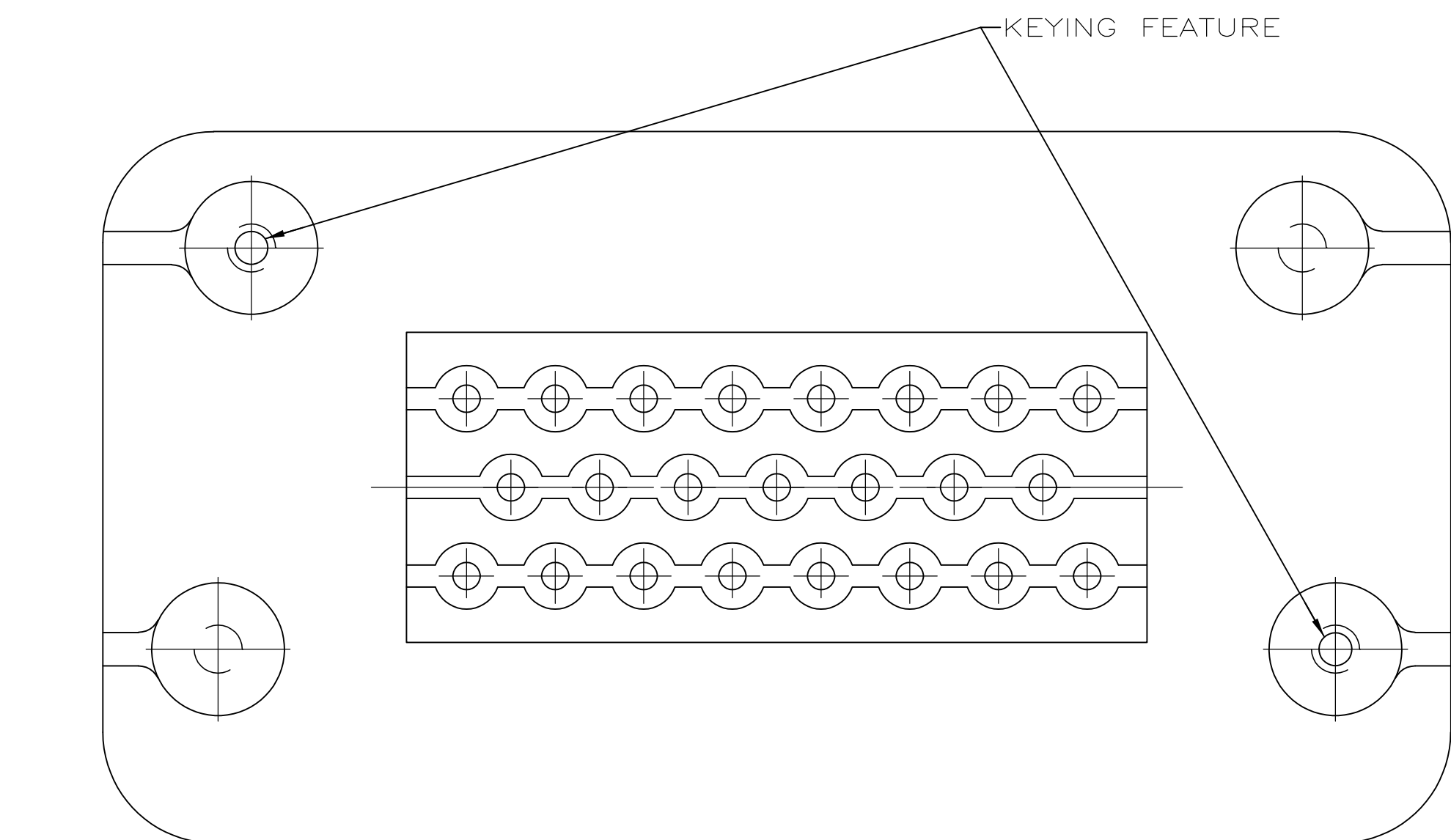

KEYING FOR 776228-1 AND 776228-5

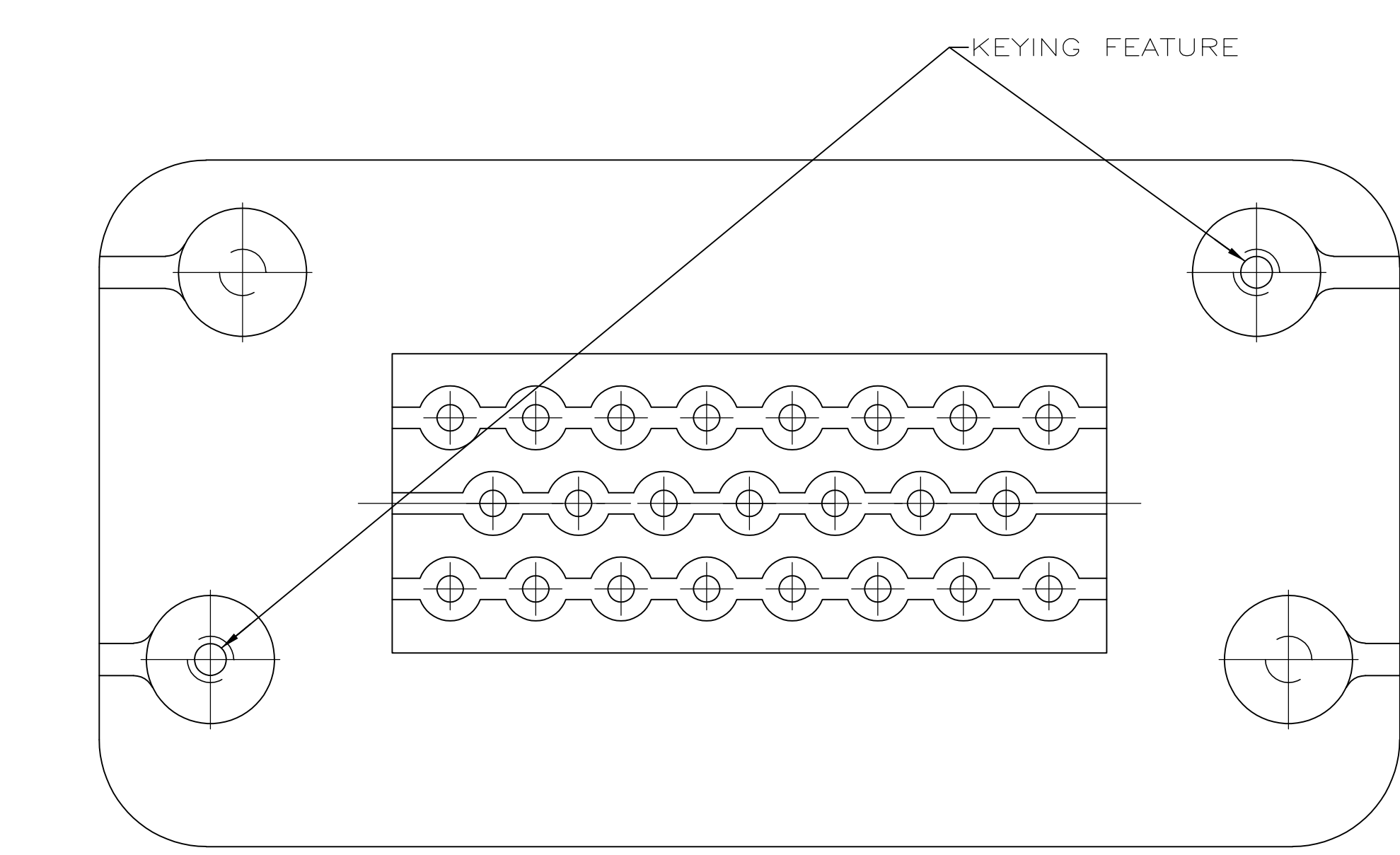

KEYING FOR 776228-2 AND 776228-4

GASKET MATERIAL	DESCRIPTION	PART NUMBER
⚠	MAKE FROM 1-776220-5	1-776228-5
⚠	MAKE FROM 1-776220-4	1-776228-4
⚠	MAKE FROM 1-776220-2	1-776228-2
⚠	MAKE FROM 1-776220-1	1-776228-1
⚠	MAKE FROM 776220-5	776228-5
⚠	MAKE FROM 776220-4	776228-4
⚠	MAKE FROM 776220-3	776228-3
⚠	MAKE FROM 776220-2	776228-2
⚠	MAKE FROM 776220-1	776228-1

THIS DRAWING IS A CONTROLLED DOCUMENT. DATE: 7-21-97. DRAWN BY: J. COLLINS. CHECKED BY: D. STILLIE. APPROVED BY: J. CROWE. PRODUCT SPEC: 109-1329. APPLICATION SPEC: 114-16016. WEIGHT: -. CUSTOMER DRAWING. SCALE: 4:1. SHEET: 1 OF 1. REV: C2.

TYCO ELECTRONICS CORPORATION, HARRISBURG, PA 17105-3608. HEADERS ASSEMBLY, 23 POSITION, VERTICAL AMPSEAL, TM.